

Revision description:			
Part name: G2HRTYPE4-01 LADDER RACK			
Finish:	Material:	Non specified radius N/A	Revision date:
 CESENATICO (FC) Via Balitrona, 12 Tel. 0039-0547-311206 Fax 0039-0547-311636	Tolerances: UNI EN 22768-1	Non specified chamfer N/A	Revision:
	Designed by: Dario Tontini	Date: 28-02-18	Scale: N/A
Checked by: M. Amadori	Thickness:	PN: G2HRTYPE4-01	
CERTIFIED COMPANY UNI EN ISO 9001:2008 NUMBER 17705/08/5			

WITHOUT OUR EXPRESS PERMISSION THIS DESIGN MAY NOT BE REPRODUCED OR PRESS TO THIRD PARTIES.

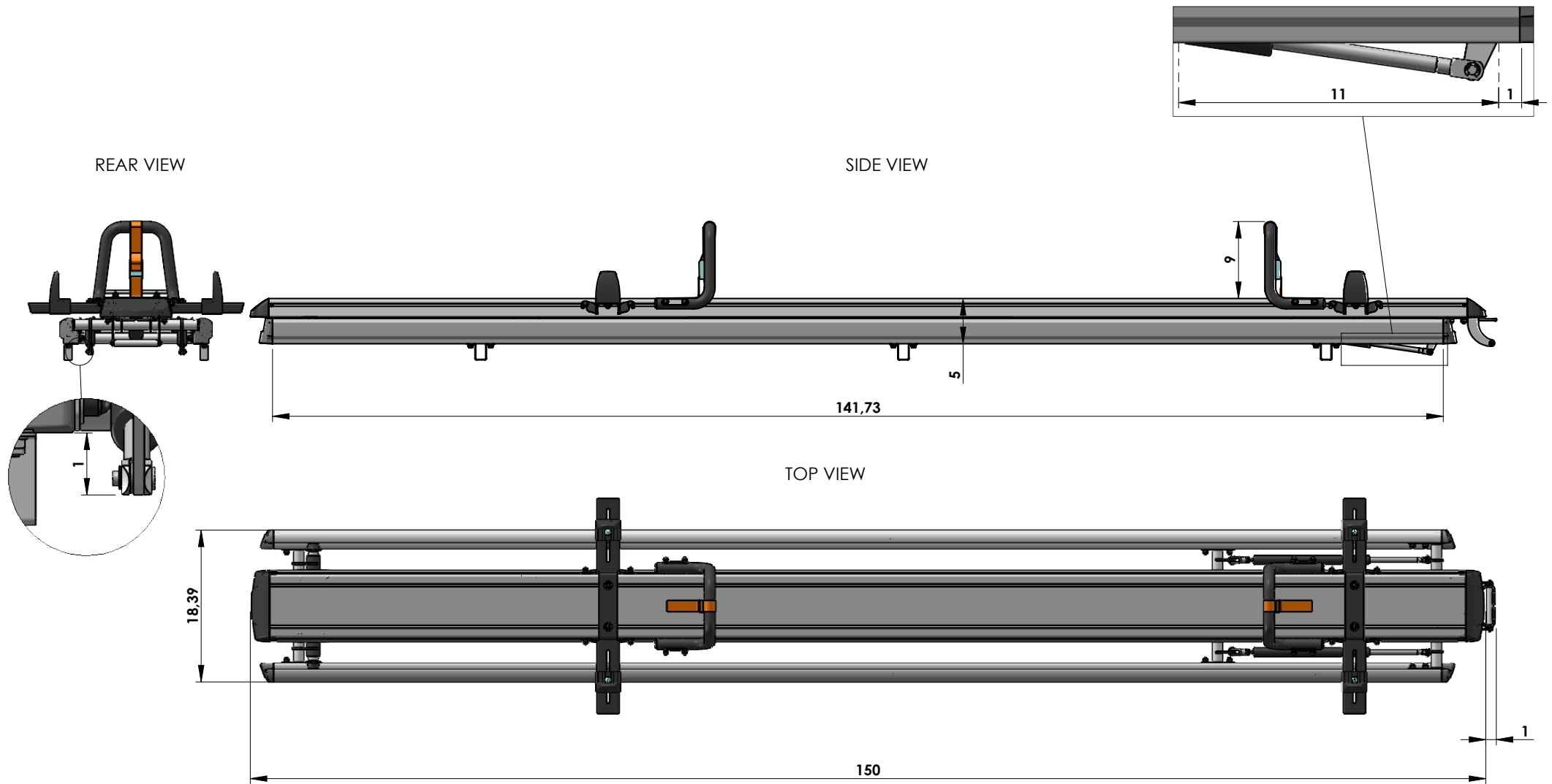

GAS STRUTS 573 lbs

Revision description:			
Part name: G2HRTYPE4-01 LADDER RACK			
Finish:	Material:	Non specified radius N/A	Revision date:
	Tolerances: UNI EN 22768-1	Non specified chamfer N/A	Revision:
	Designed by: Dario Tontini	Date: 28-02-18	Scale: N/A
Checked by: M. Amadori	Thickness:	PN: G2HRTYPE4-01	
CESENATICO (FC) Via Balitrona, 12 Tel. 0039-0547-311206 Fax 0039-0547-311636 CERTIFIED COMPANY UNI EN ISO 9001:2008 NUMBER 17705/08/5			

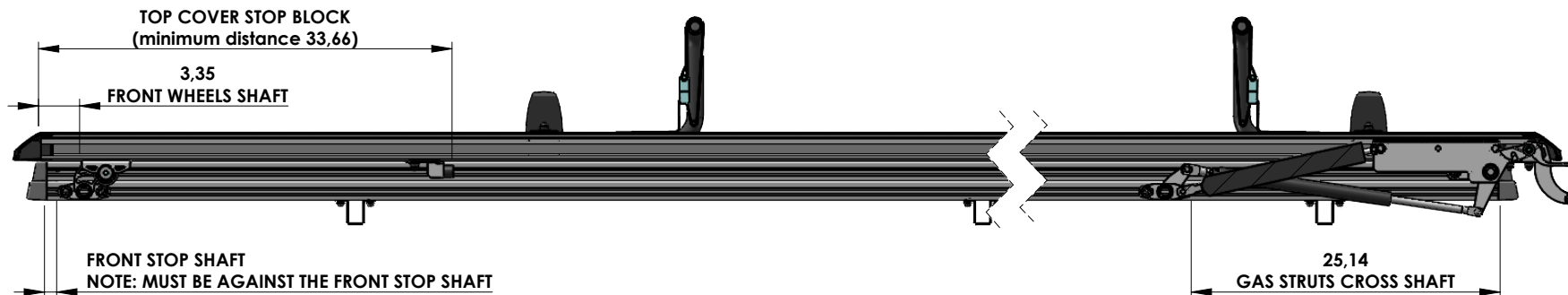

WITHOUT OUR EXPRESS PERMISSION THIS DESIGN MAY NOT BE REPRODUCED OR PRESS TO THIRD PARTIES.

SECTION A-A

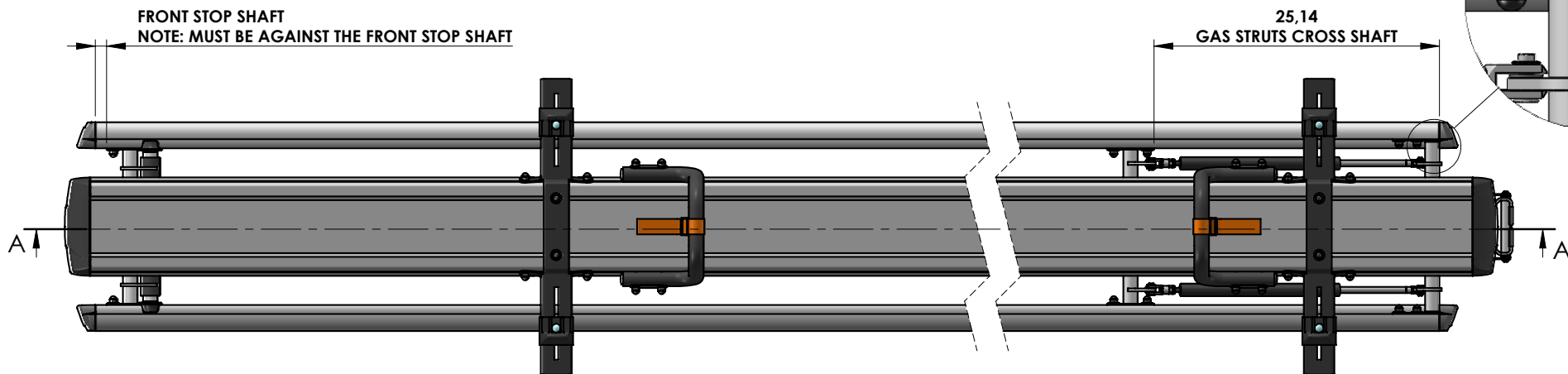
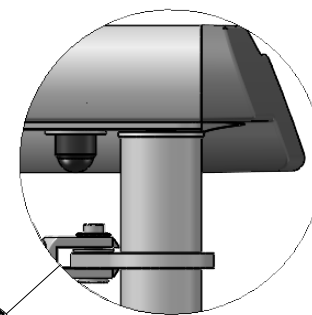

CENTRAL MECHANISM TO BE ALIGNED WITH THE ENDS OF THE SIDE RAILS



Revision description:			
Part name: G2HRTYPE4-01 LADDER RACK			
Finish:	Material:	Non specified radius N/A	Revision date:
	Tolerances: UNI EN 22768-1	Non specified chamfer N/A	Revision:
	Designed by: Dario Tontini	Date: 28-02-18	Scale: N/A 
CESENATICO (FC) Via Balitrona, 12 Tel. 0039-0547-311206 Fax 0039-0547-311636	Checked by: M. Amadori	Thickness:	PN: G2HRTYPE4-01
CERTIFIED COMPANY UNI EN ISO 9001:2008 NUMBER 17705/08/5			

WITHOUT OUR EXPRESS PERMISSION THIS DESIGN MAY NOT BE REPRODUCED OR PRESS TO THIRD PARTIES.