



Revision description:			
Part name: G2HRTYPE3MAXI-H2 LADDER RACK			
Finish:	Material:	Non specified radius N/A	Revision date:
	Tolerances: UNI EN 22768-1	Non specified chamfer N/A	Revision:
	Designed by: Nicolò	Date: 30-01-17	Scale: N/A 
CESENATICO (FC) Via Balitrona, 12 Tel. 0039-0547-311206 Fax 0039-0547-311636	Checked by: M. Amadori	Thickness:	PN: G2HRTYPE3MAXI-H2
CERTIFIED COMPANY UNI EN ISO 9001:2008 NUMBER 17705/08/5			

WITHOUT OUR EXPRESS PERMISSION THIS DESIGN MAY NOT BE REPRODUCED OR PRESS TO THIRD PARTIES.



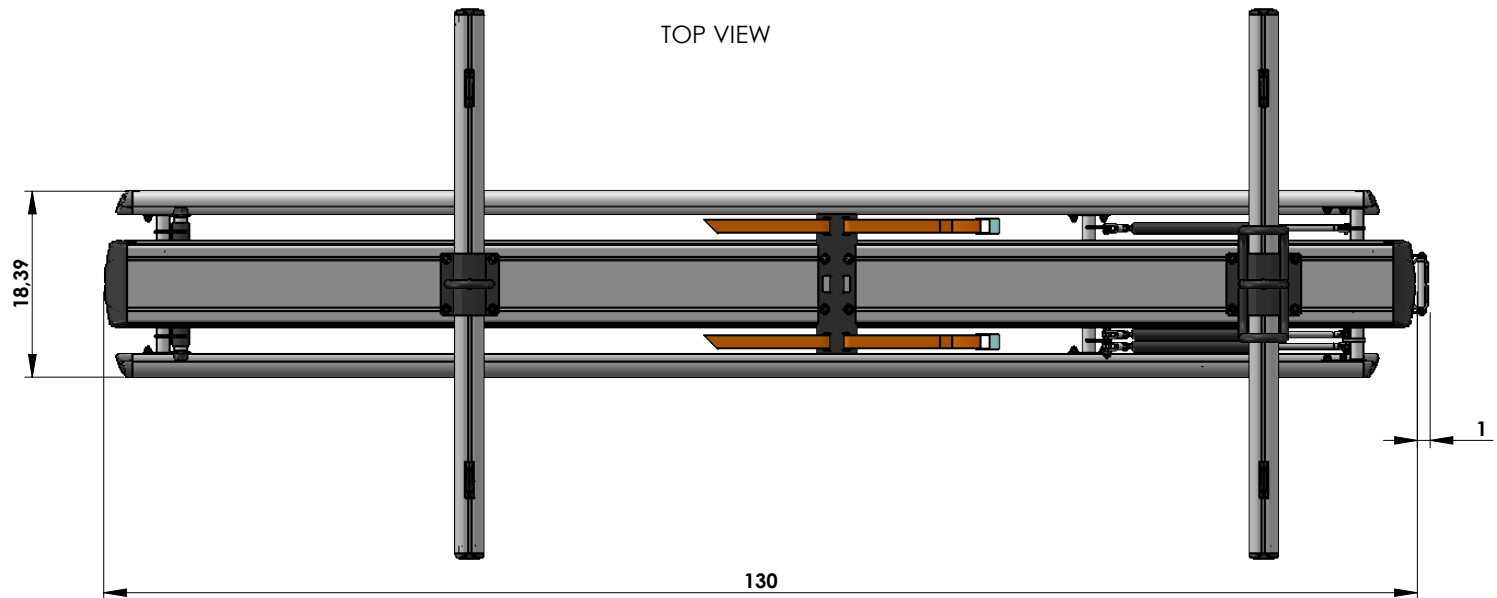
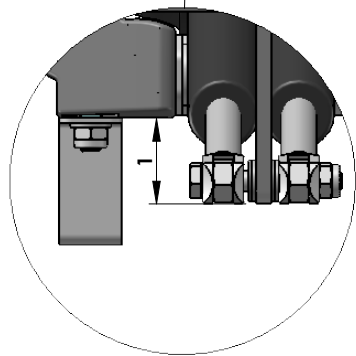
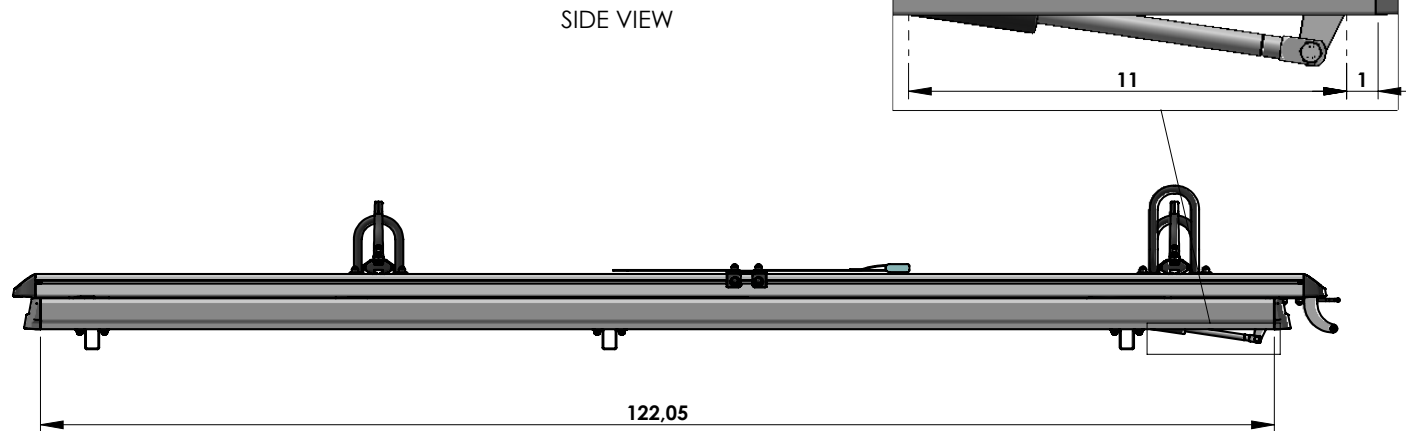
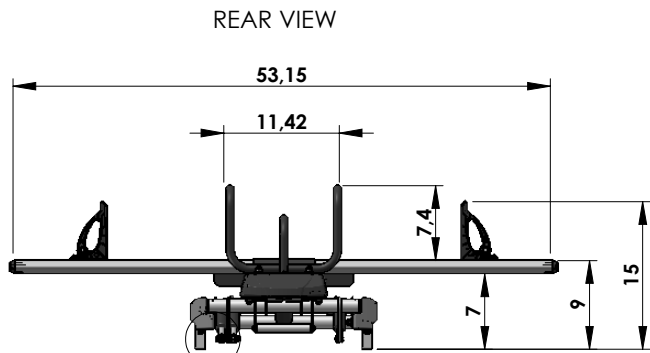
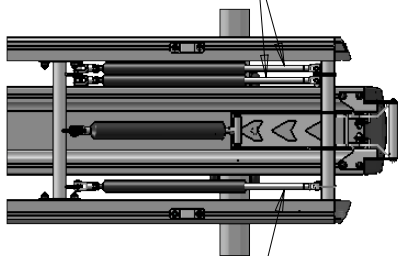

LOWER VIEW
 GAS STRUTS 573 lbs
 GAS STRUTS 220 lbs

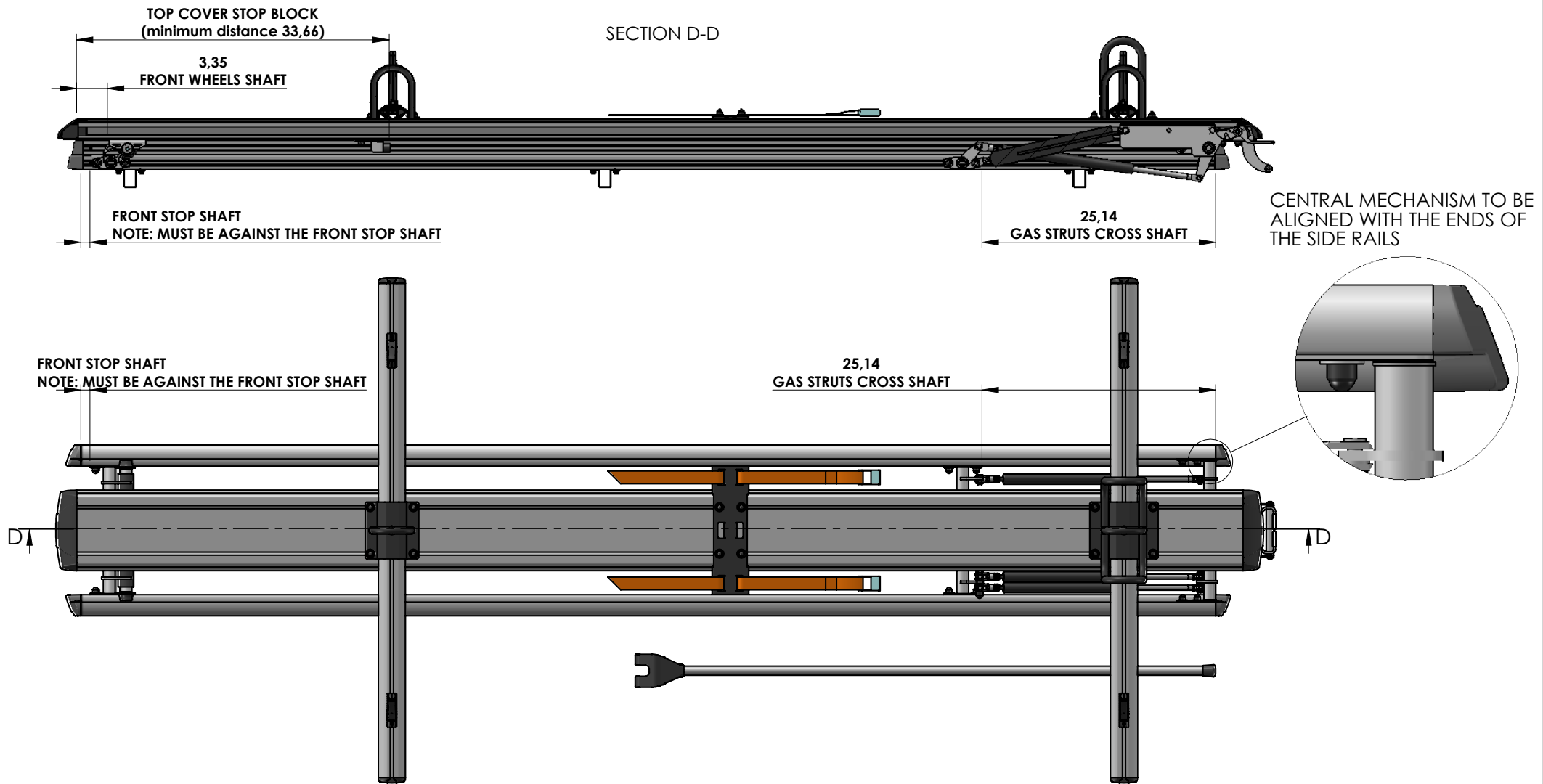

GAS STRUTS 573 lbs

Revision description:			
Part name: G2HRTYPE3MAXI-H2 LADDER RACK			
Finish:	Material:	Non specified radius N/A	Revision date:
	Tolerances: UNI EN 22768-1	Non specified chamfer N/A	Revision:
	Designed by: Nicolò	Date: 30-01-17	Scale: N/A
Checked by: M. Amadori	Thickness:	PN: G2HRTYPE3MAXI-H2	
CESENATICO (FC) Via Balitrona, 12 Tel. 0039-0547-311206 Fax 0039-0547-311636 CERTIFIED COMPANY UNI EN ISO 9001:2008 NUMBER 17705/08/5			



Revision description:			
Part name: G2HRTYPE3MAXI-H2 LADDER RACK			
Finish:	Material:	Non specified radius N/A	Revision date:
	Tolerances: UNI EN 22768-1	Non specified chamfer N/A	Revision:
	Designed by: Nicolò	Date: 30-01-17	Scale: N/A 
CESENATICO (FC) Via Balitrona, 12 Tel. 0039-0547-311206 Fax 0039-0547-311636	Checked by: M. Amadori	Thickness:	PN: G2HRTYPE3MAXI-H2
CERTIFIED COMPANY UNI EN ISO 9001:2008 NUMBER 17705/08/5			

WITHOUT OUR EXPRESS PERMISSION THIS DESIGN MAY NOT BE REPRODUCED OR PRESS TO THIRD PARTIES.