





| | | | |
|---|----------------------------|------------------------------|--|
| Revision description: | | | |
| Part name: G2HRTYPE3-01 LADDER RACK | | | |
| Finish: | Material: | Non specified radius N/A | Revision date: |
|  | Tolerances: UNI EN 22768-1 | Non specified chamfer N/A | Revision: |
| | Designed by: Dario Tontini | Date: 27-08-18 | Scale: N/A  |
| CESENATICO (FC) Via Balitrona, 12 Tel. 0039-0547-311206 Fax 0039-0547-311636 | Checked by: M. Amadori | Thickness: | PN: G2HRTYPE3-01 |
| CERTIFIED COMPANY UNI EN ISO 9001:2008 NUMBER 17705/08/5 | | | |

WITHOUT OUR EXPRESS PERMISSION THIS DESIGN MAY NOT BE REPRODUCED OR PRESS TO THIRD PARTIES.

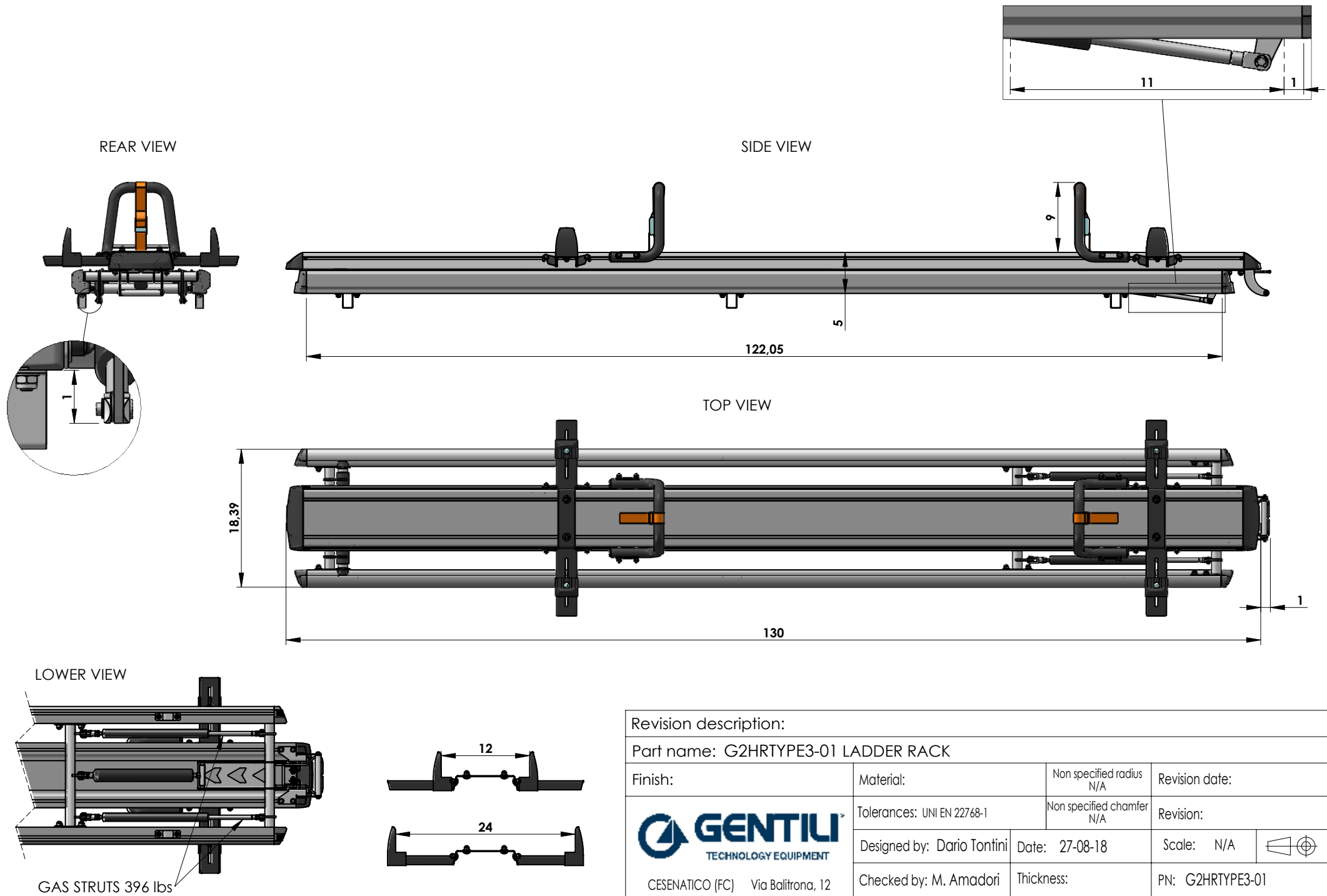

| | | | |
|---|----------------------------|------------------------------|----------------|
| Revision description: | | | |
| Part name: G2HRTYPE3-01 LADDER RACK | | | |
| Finish: | Material: | Non specified radius N/A | Revision date: |
|  | Tolerances: UNI EN 22768-1 | Non specified chamfer N/A | Revision: |
| | Designed by: Dario Tontini | Date: 27-08-18 | Scale: N/A |
| Checked by: M. Amadori | Thickness: | PN: G2HRTYPE3-01 | |
| CESENATICO (FC) Via Balitrona, 12 Tel. 0039-0547-311206 Fax 0039-0547-311636 | | | |
| CERTIFIED COMPANY UNI EN ISO 9001:2008 NUMBER 17705/08/5 | | | |

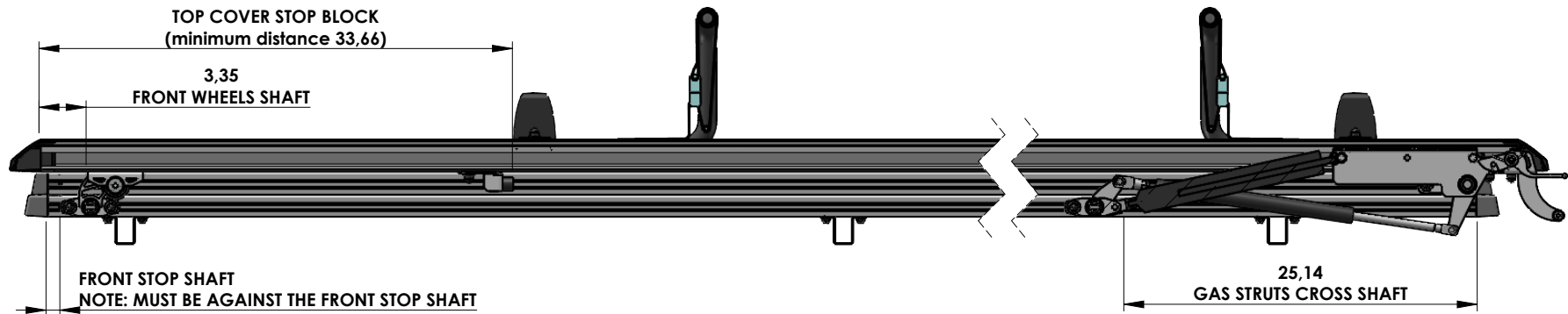

WITHOUT OUR EXPRESS PERMISSION THIS DESIGN MAY NOT BE REPRODUCED OR PRESS TO THIRD PARTIES.

SECTION A-A

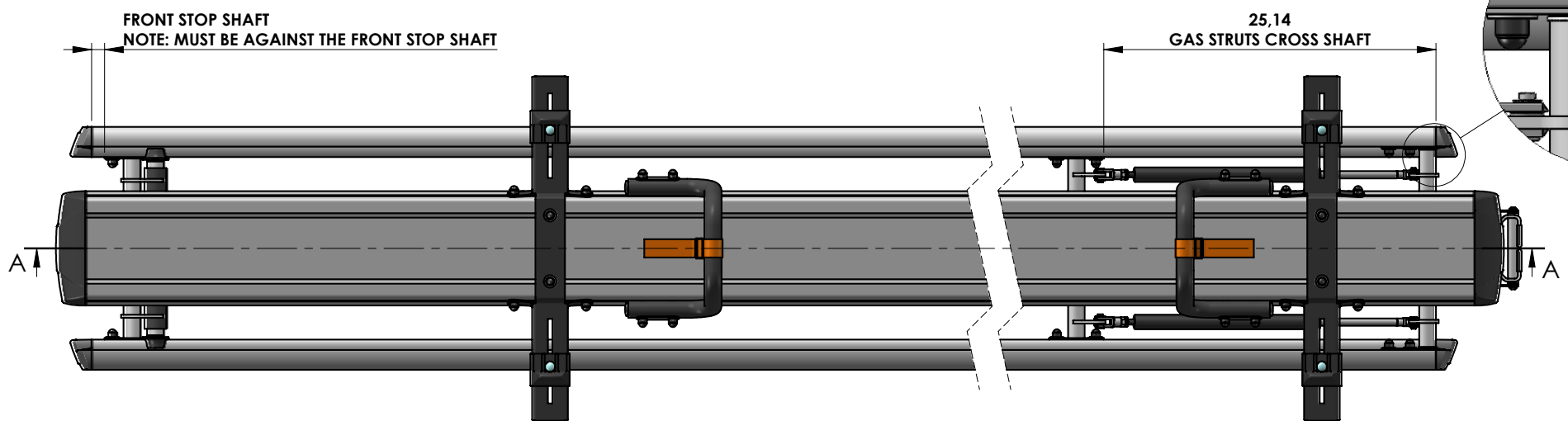

CENTRAL MECHANISM TO BE ALIGNED WITH THE ENDS OF THE SIDE RAILS



| | | | |
|---|----------------------------|------------------------------|--|
| Revision description: | | | |
| Part name: G2HRTYPE3-01 LADDER RACK | | | |
| Finish: | Material: | Non specified radius N/A | Revision date: |
|  | Tolerances: UNI EN 22768-1 | Non specified chamfer N/A | Revision: |
| | Designed by: Dario Tontini | Date: 27-08-18 | Scale: N/A  |
| CESENATICO (FC) Via Balitrona, 12 Tel. 0039-0547-311206 Fax 0039-0547-311636 | Checked by: M. Amadori | Thickness: | PN: G2HRTYPE3-01 |
| CERTIFIED COMPANY UNI EN ISO 9001:2008 NUMBER 17705/08/5 | | | |

WITHOUT OUR EXPRESS PERMISSION THIS DESIGN MAY NOT BE REPRODUCED OR PRESS TO THIRD PARTIES.