



Revision description:			
Part name: G2HRYPE2-01 LADDER RACK			
Finish:	Material:	Non specified radius N/A	Revision date:
	Tolerances: UNI EN 22768-1	Non specified chamfer N/A	Revision:
	Designed by: Dario Tontini	Date: 28-02-18	Scale: N/A 
CESENATICO (FC) Via Balitrona, 12 Tel. 0039-0547-311206 Fax 0039-0547-311636	Checked by: M. Amadori	Thickness:	PN: G2HRYPE2-01
CERTIFIED COMPANY UNI EN ISO 9001:2008 NUMBER 17705/08/5			

WITHOUT OUR EXPRESS PERMISSION THIS DESIGN MAY NOT BE REPRODUCED OR PRESS TO THIRD PARTIES.

REAR VIEW

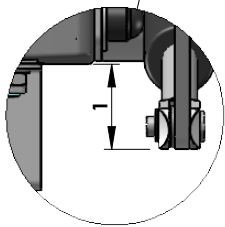
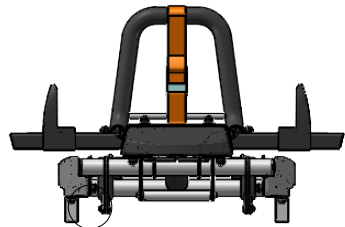

SIDE VIEW

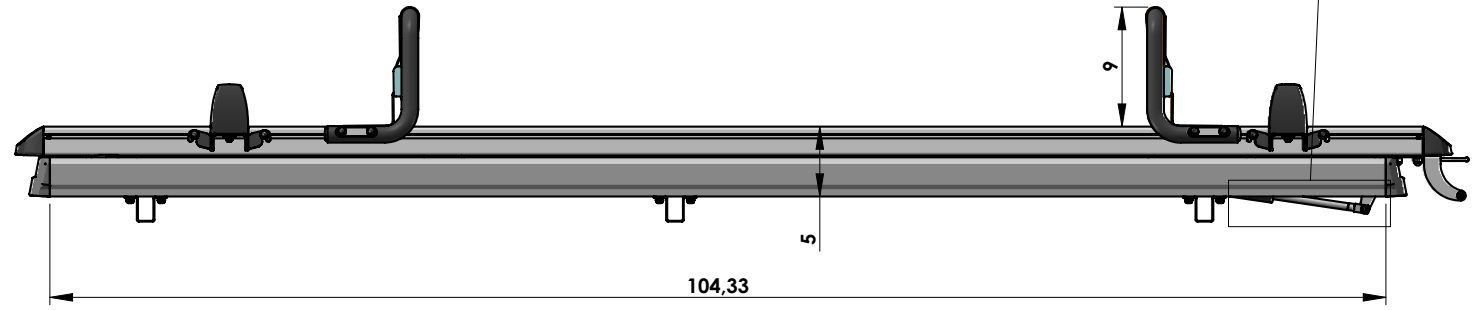

TOP VIEW

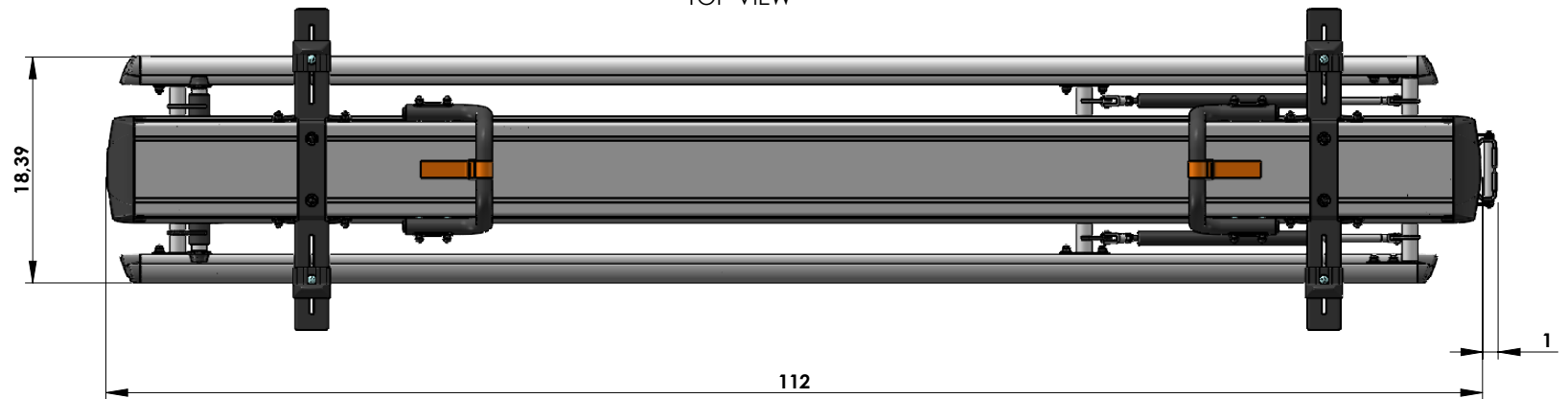

LOWER VIEW

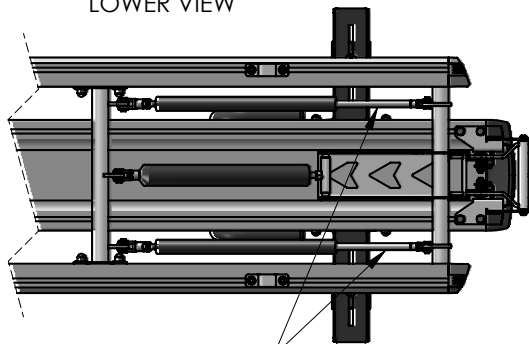

GAS STRUTS 220 lbs

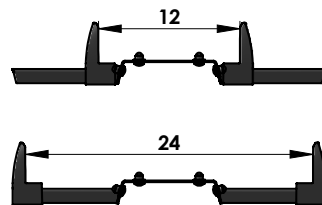

Revision description:

Part name: G2HRTYPE2-01 LADDER RACK

Finish:

Material:

Non specified radius
N/A

Revision date:



Tolerances: UNI EN 22768-1

Non specified chamfer
N/A

Revision:

Designed by: Dario Tontini

Date: 28-02-18

Scale: N/A



Checked by: M. Amadori

Thickness:

PN: G2HRTYPE2-01

CESENATICO (FC) Via Balitrona, 12
Tel. 0039-0547-311206 Fax 0039-0547-311636

CERTIFIED COMPANY UNI EN ISO 9001:2008 NUMBER 17705/08/5

WITHOUT OUR EXPRESS PERMISSION THIS DESIGN MAY NOT BE REPRODUCED OR PRESS TO THIRD PARTIES.

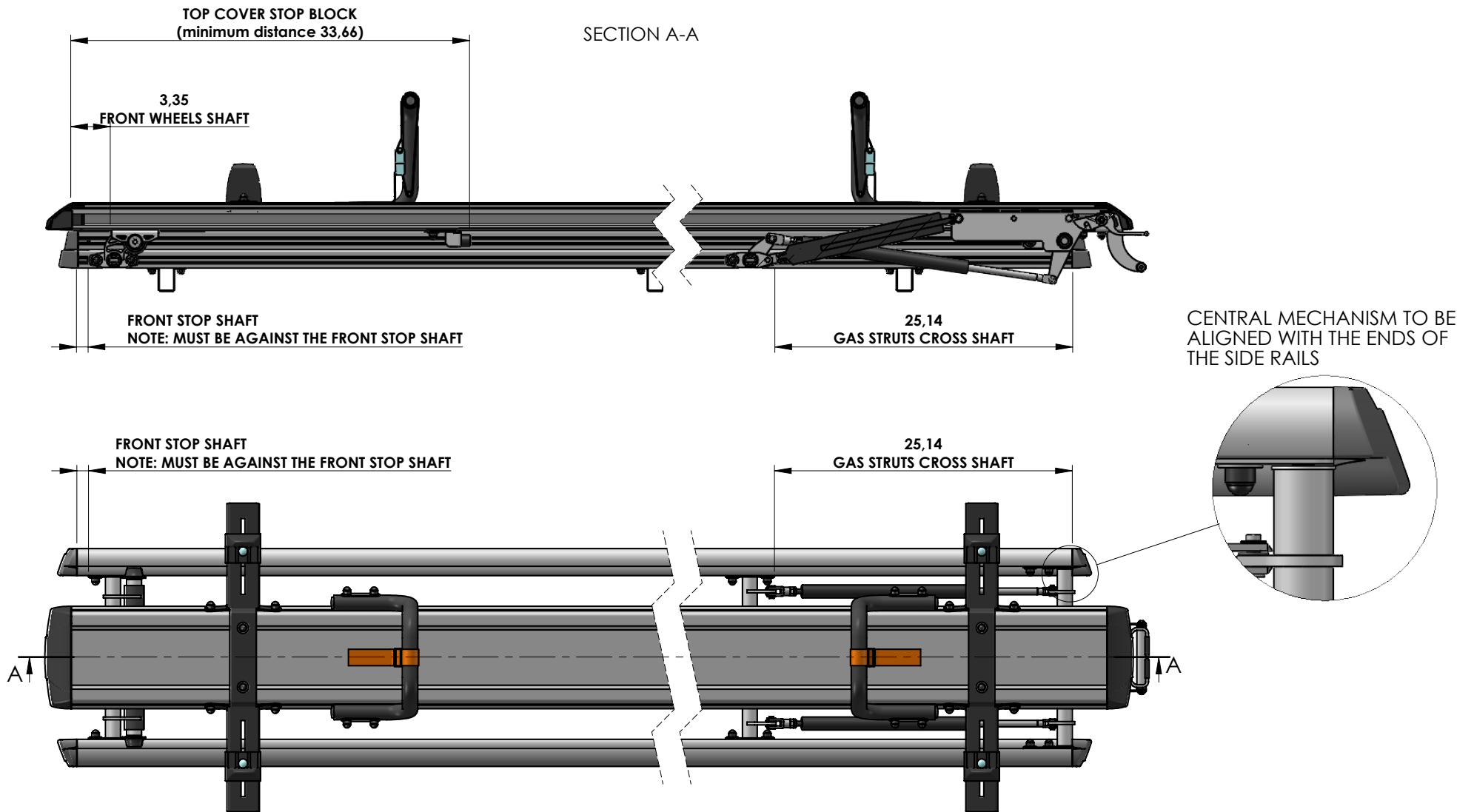

Revision description:			
Part name: G2HRTYPE2-01 LADDER RACK			
Finish:	Material:	Non specified radius N/A	Revision date:
	Tolerances: UNI EN 22768-1	Non specified chamfer N/A	Revision:
	Designed by: Dario Tontini	Date: 28-02-18	Scale: N/A
CESENATICO (FC) Via Balitrona, 12 Tel. 0039-0547-311206 Fax 0039-0547-311636	Checked by: M. Amadori	Thickness:	PN: G2HRTYPE2-01
CERTIFIED COMPANY UNI EN ISO 9001:2008 NUMBER 17705/08/5			

WITHOUT OUR EXPRESS PERMISSION THIS DESIGN MAY NOT BE REPRODUCED OR PRESS TO THIRD PARTIES.