



Revision description:			
Part name: G2HRTYPE1MAXI LADDER RACK			
Finish:	Material:	Non specified radius N/A	Revision date:
	Tolerances: UNI EN 22768-1	Non specified chamfer N/A	Revision:
	Designed by: Nicolò	Date: 14-03-16	Scale: N/A 
CESENATICO (FC) Via Balitrona, 12 Tel. 0039-0547-311206 Fax 0039-0547-311636	Checked by: M. Amadori	Thickness:	PN: G2HRTYPE1MAXI
CERTIFIED COMPANY UNI EN ISO 9001:2008 NUMBER 17705/08/5			

WITHOUT OUR EXPRESS PERMISSION THIS DESIGN MAY NOT BE REPRODUCED OR PRESS TO THIRD PARTIES.

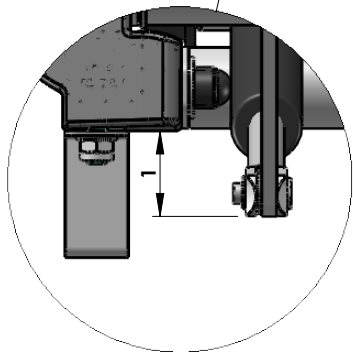
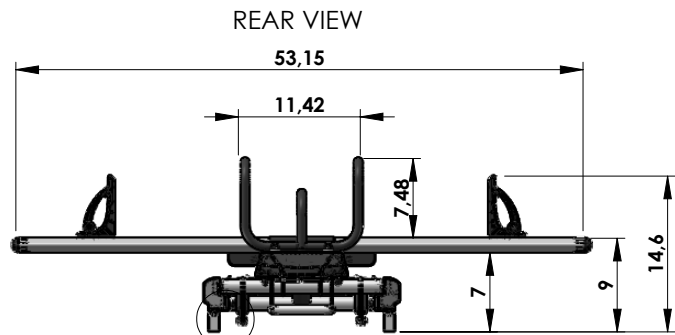

LOWER VIEW

GAS STRUTS 220 lbs

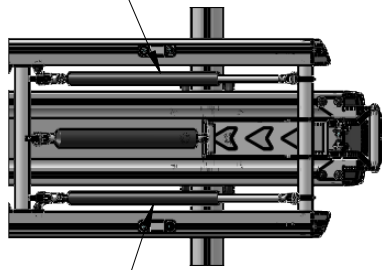

GAS STRUTS 220 lbs

SIDE VIEW

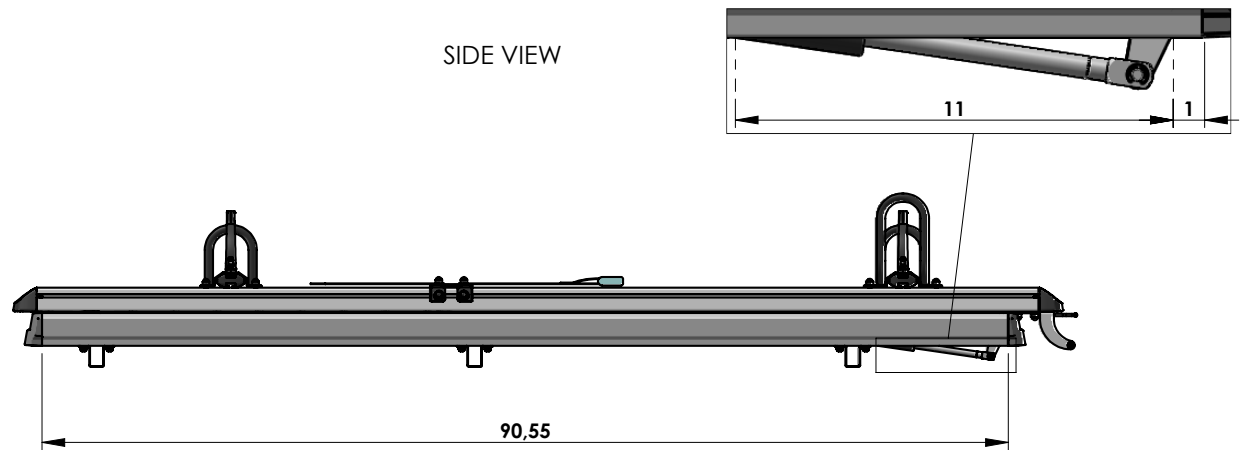

TOP VIEW

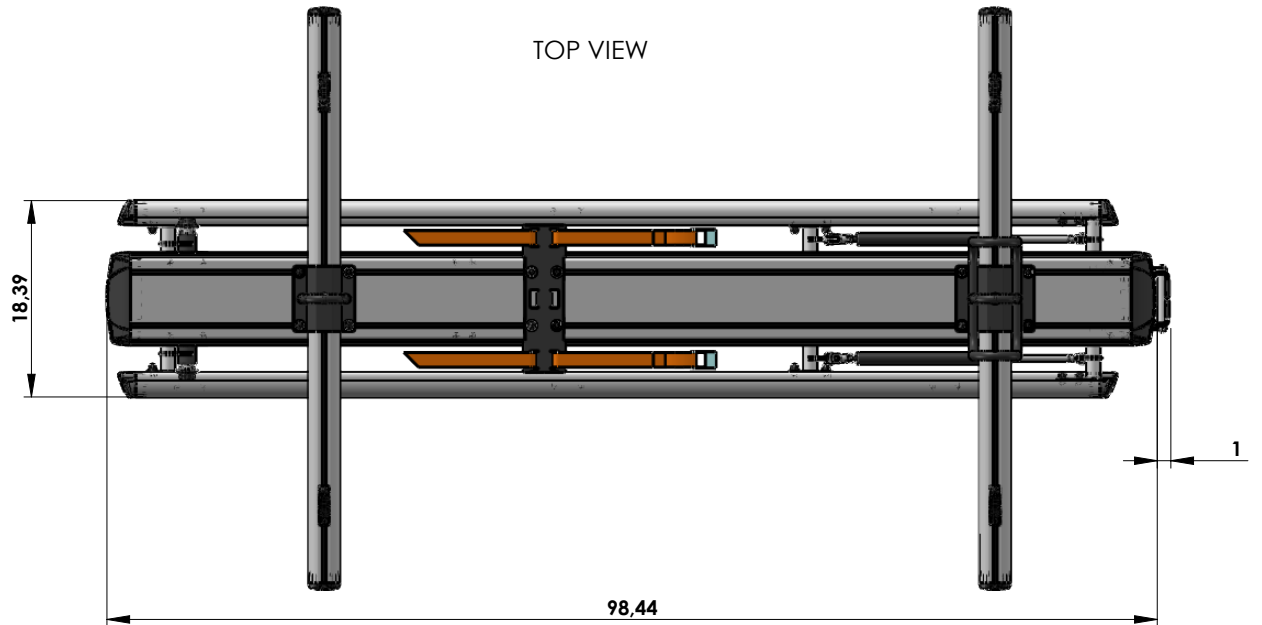

Revision description:

Part name: G2HRTYPE1MAXI LADDER RACK

Finish:	Material:	Non specified radius N/A	Revision date:
	Tolerances: UNI EN 22768-1	Non specified chamfer N/A	Revision:
	Designed by: Nicolò	Date: 14-03-16	Scale: N/A
Checked by: M. Amadori	Thickness:	PN: G2HRTYPE1MAXI	

CESENATICO (FC) Via Balitrona, 12
Tel. 0039-0547-311206 Fax 0039-0547-311636

CERTIFIED COMPANY UNI EN ISO 9001:2008 NUMBER 17705/08/5

WITHOUT OUR EXPRESS PERMISSION THIS DESIGN MAY NOT BE REPRODUCED OR PRESS TO THIRD PARTIES.

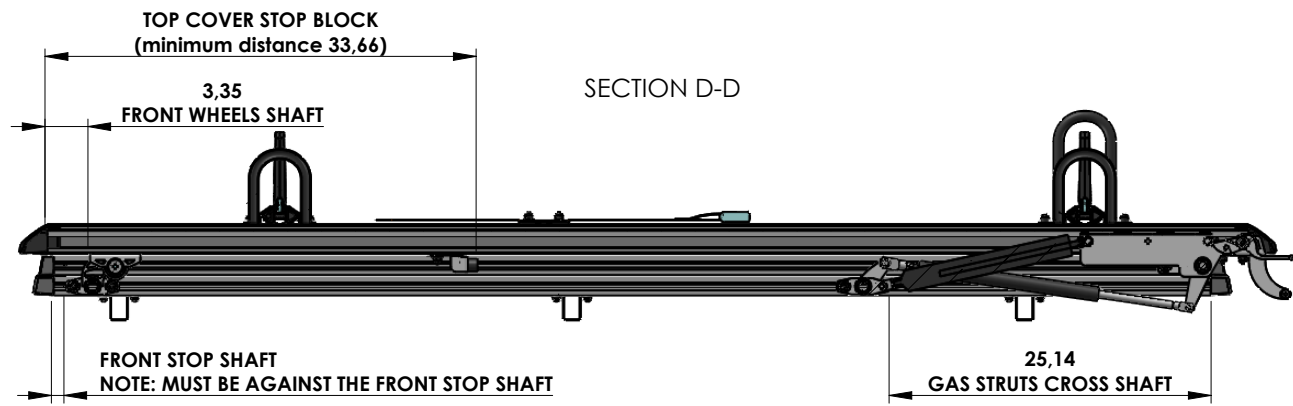

CENTRAL MECHANISM TO BE
ALIGNED WITH THE ENDS OF
THE SIDE RAILS

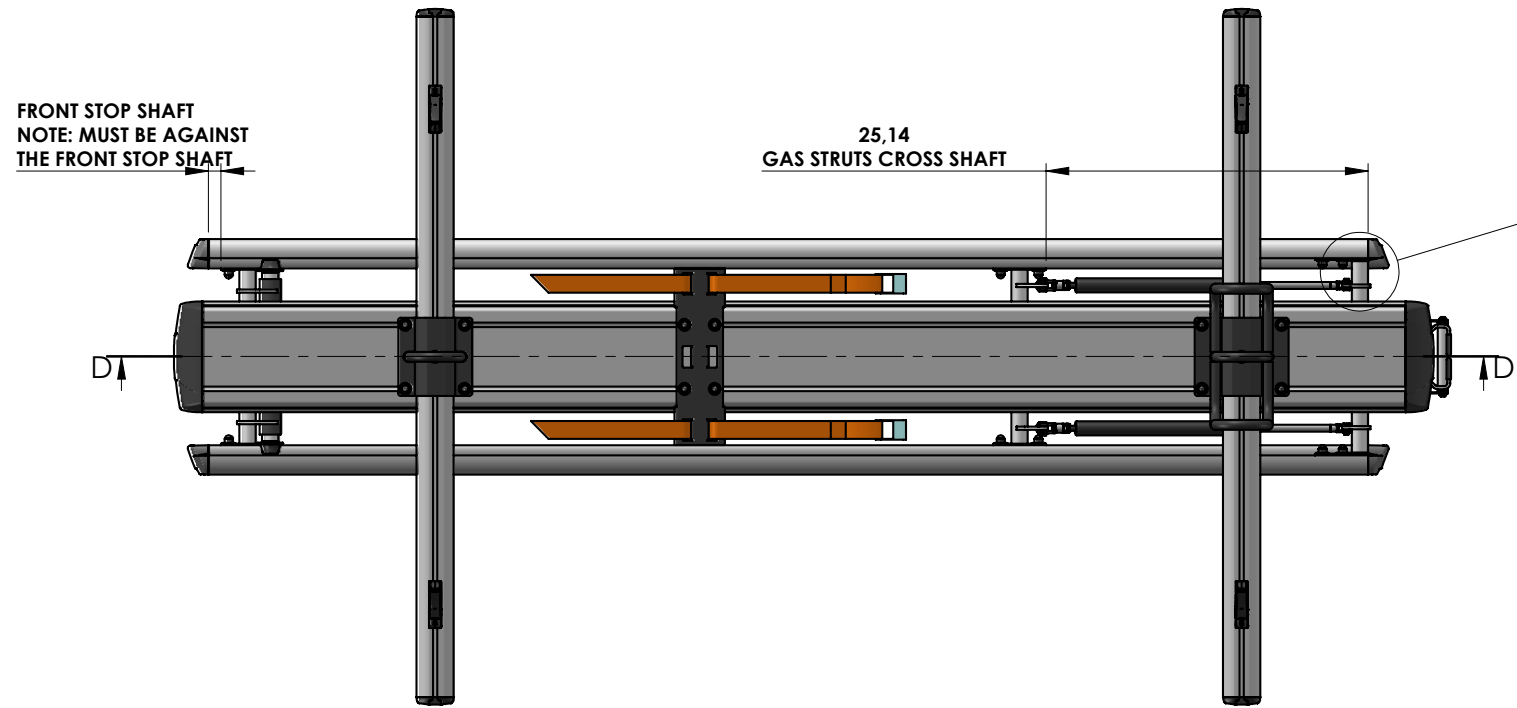
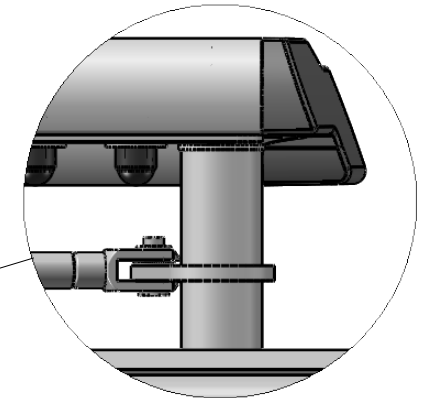

Revision description:			
Part name: G2HRTYPE1MAXI LADDER RACK			
Finish:	Material:	Non specified radius N/A	Revision date:
	Tolerances: UNI EN 22768-1	Non specified chamfer N/A	Revision:
	Designed by: Nicolò	Date: 14-03-16	Scale: N/A
CESENATICO (FC) Via Ballitrona, 12 Tel. 0039-0547-311206 Fax 0039-0547-311636	Checked by: M. Amadori	Thickness:	PN: G2HRTYPE1MAXI
CERTIFIED COMPANY UNI EN ISO 9001:2008 NUMBER 17705/08/5			

WITHOUT OUR EXPRESS PERMISSION THIS DESIGN MAY NOT BE REPRODUCED OR PRESS TO THIRD PARTIES.