



Revision description:			
Part name: G2HRTYPE1-01 LADDER RACK			
Finish:	Material:	Non specified radius N/A	Revision date:
	Tolerances: UNI EN 22768-1	Non specified chamfer N/A	Revision:
	Designed by: Dario Tontini	Date: 12-12-17	Scale: N/A 
CESENATICO (FC) Via Balitrona, 12 Tel. 0039-0547-311206 Fax 0039-0547-311636	Checked by: M. Amadori	Thickness:	PN: G2HRTYPE1-01
CERTIFIED COMPANY UNI EN ISO 9001:2008 NUMBER 17705/08/5			

WITHOUT OUR EXPRESS PERMISSION THIS DESIGN MAY NOT BE REPRODUCED OR PRESS TO THIRD PARTIES.



REAR VIEW

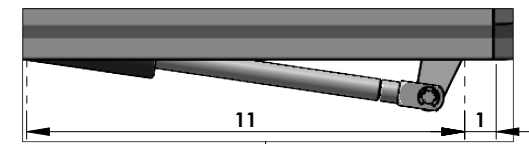
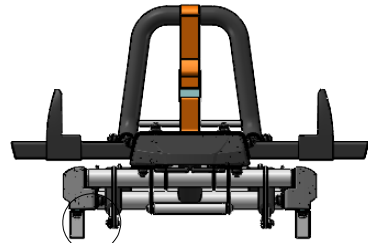

SIDE VIEW

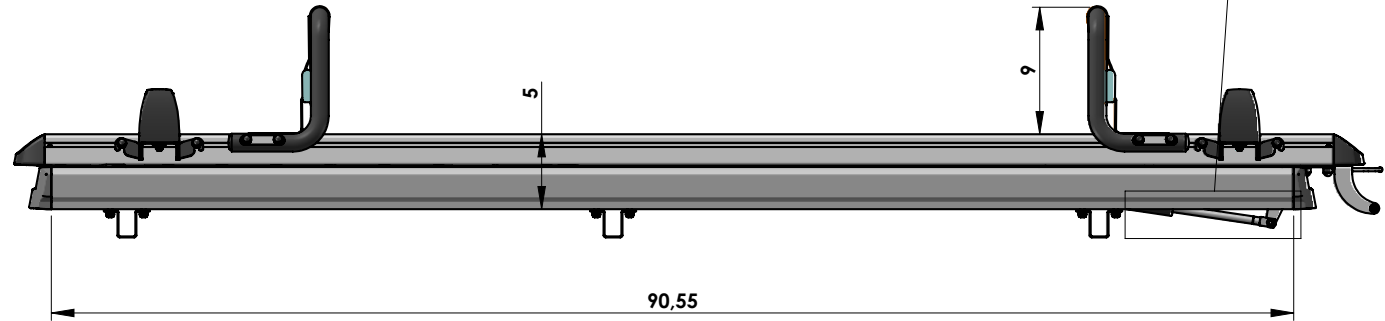

TOP VIEW

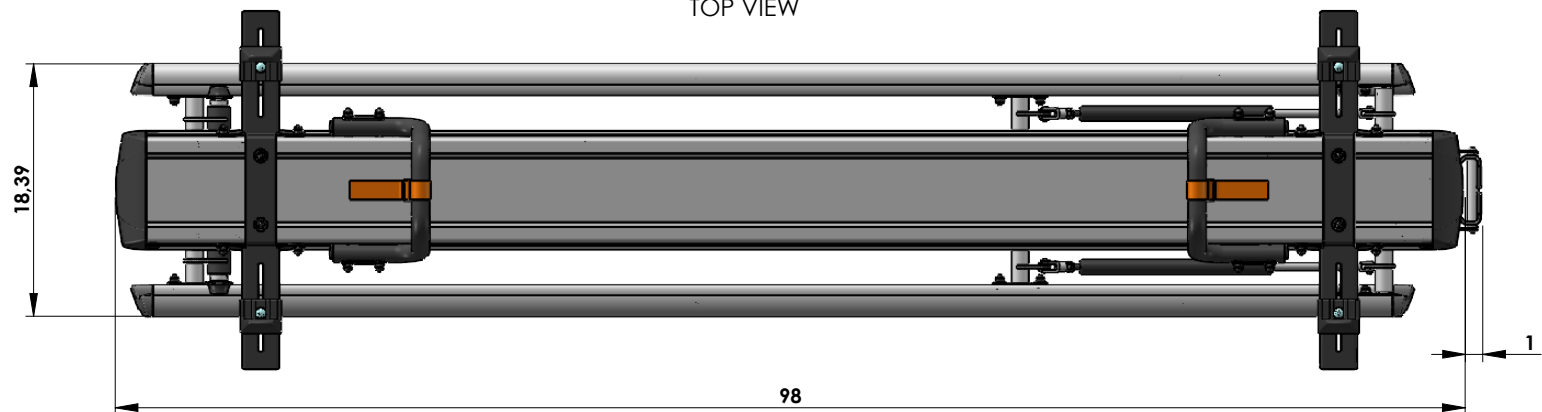

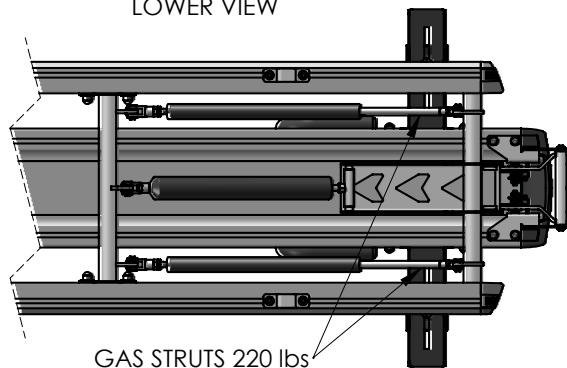

LOWER VIEW

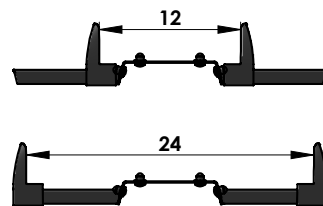

GAS STRUTS 220 lbs



Revision description:			
Part name: G2HRTYPE1-01 LADDER RACK			
Finish:	Material:	Non specified radius N/A	Revision date:
	Tolerances: UNI EN 22768-1	Non specified chamfer N/A	Revision:
	Designed by: Dario Tontini	Date: 12-12-17	Scale: N/A 
CESENATICO (FC) Via Balitrona, 12 Tel. 0039-0547-311206 Fax 0039-0547-311636	Checked by: M. Amadori	Thickness:	PN: G2HRTYPE1-01
CERTIFIED COMPANY UNI EN ISO 9001:2008 NUMBER 17705/08/5			

WITHOUT OUR EXPRESS PERMISSION THIS DESIGN MAY NOT BE REPRODUCED OR PRESS TO THIRD PARTIES.

SECTION A-A

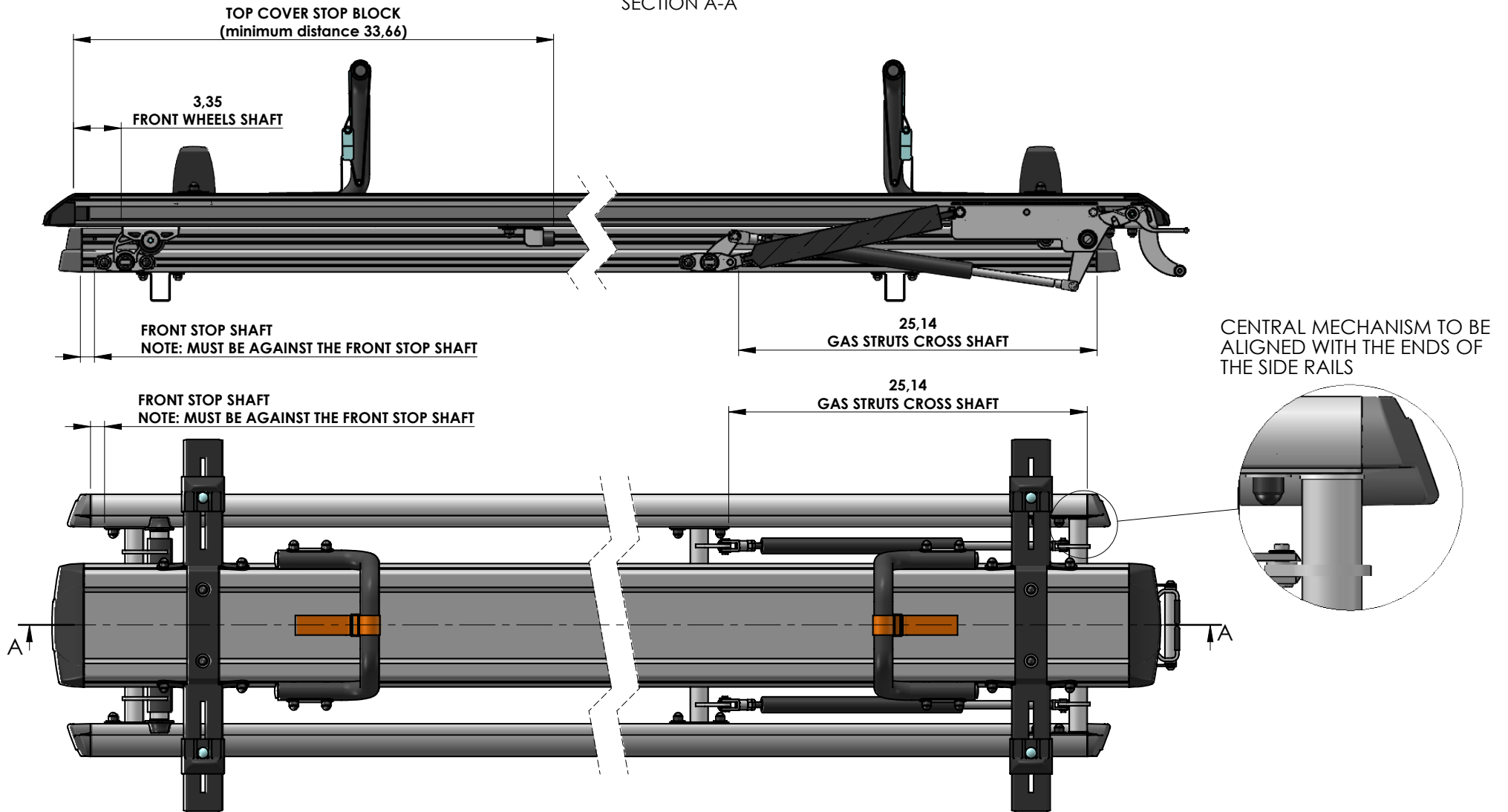

Revision description:

Part name: G2HRTYPE1-01 LADDER RACK

Finish:	Material:	Non specified radius N/A	Revision date:
	Tolerances: UNI EN 22768-1	Non specified chamfer N/A	Revision:
	Designed by: Dario Tontini	Date: 12-12-17	Scale: N/A
CESENATICO (FC) Via Balitrona, 12 Tel. 0039-0547-311206 Fax 0039-0547-311636	Checked by: M. Amadori	Thickness:	PN: G2HRTYPE1-01
CERTIFIED COMPANY UNI EN ISO 9001:2008 NUMBER 17705/08/5			

WITHOUT OUR EXPRESS PERMISSION THIS DESIGN MAY NOT BE REPRODUCED OR PRESS TO THIRD PARTIES.